

CLARKE®



900W HAMMER DRILL

MODEL NO: CHD900

PART NO: 6479504

OPERATION & MAINTENANCE INSTRUCTIONS



ORIGINAL INSTRUCTIONS

GC09/22

INTRODUCTION

Thank you for purchasing this CLARKE Hammer Drill.

Before attempting to use this product, please read this manual thoroughly and follow the instructions carefully. In doing so you will ensure the safety of yourself and that of others around you, and you can look forward to your purchase giving you long and satisfactory service.

Please keep these instructions in a safe place for future reference.

ENVIRONMENTAL PROTECTION







Recycle unwanted materials instead of disposing of them as waste. All tools, accessories and packaging should be sorted, taken to a recycling centre and disposed of in a manner which is compatible with the environment.

Through purchase of this product, the customer is taking on the obligation to deal with the WEEE in accordance with the WEEE regulations in relation to the treatment, recycling & recovery and environmentally sound disposal of the WEEE.

In effect, this means that this product must not be disposed of with general household waste. It must be disposed of according to the laws governing Waste Electrical and Electronic Equipment (WEEE) at a recognised disposal facility.

SAFETY SYMBOLS

	Read instruction manual before use		Wear ear defenders
	Wear dust mask		Wear safety glasses

The above safety symbols may appear on the product.

SAFETY PRECAUTIONS



WARNING: READ ALL INSTRUCTIONS. FAILURE TO FOLLOW ALL INSTRUCTIONS LISTED BELOW MAY RESULT IN ELECTRIC SHOCK, FIRE AND/OR SERIOUS INJURY. THE TERM "POWER TOOL" IN ALL WARNINGS LISTED BELOW REFERS TO YOUR 900W HAMMER DRILL.

WORK AREA

1. **Keep work area clean and well lit.** Cluttered and dark areas invite accidents.
2. **DO NOT operate power tools in explosive atmospheres, such as in the presence of flammable liquids, gases or dust.** Power tools create sparks which may ignite the dust or fumes.
3. **Keep children and bystanders away while operating a power tool.** Distractions can cause you to lose control.
4. **Avoid body contact with earthed or grounded surfaces such as pipes, radiators, ranges or refrigerators.** There is an increased risk of electric shock if your body is earthed or grounded.
5. **DO NOT expose power tools to rain or wet conditions.** Water entering a power tool will increase the risk of electric shock.
6. **When operating a power tool outdoors, use an extension cable suitable for outdoor use.** Use of a cable suitable for outdoor use reduces the risk of electric shock.

PERSONAL SAFETY

1. **Stay alert, watch what you are doing and use common sense when operating a power tool. DO NOT use a power tool while you are tired or under the influence of drugs, alcohol or medication.** A moment of inattention while operating power tools may result in personal injury.
2. **Use safety equipment. Always wear eye protection.** Safety equipment such as dust mask, non-skid safety shoes, or hearing protection used for appropriate conditions will reduce personal injuries.
3. **Avoid accidental starting. Ensure the switch is in the off position before connecting to the power supply.**
4. **DO NOT overreach. Keep proper footing and balance at all times.** This enables better control of the power tool in unexpected situations.
5. **Dress properly. Do not wear loose clothing or jewellery. Keep your hair, clothing and gloves away from moving parts.** Loose clothes, jewellery or long hair can be caught in moving parts.

POWER TOOL USE AND CARE

1. **DO NOT force the power tool. Use the correct power tool for your application.** The correct power tool will do the job better and safer at the rate which it was designed.
2. **DO NOT use the power tool if the switch does not turn it on and off.** Any power tool that cannot be controlled with the switch is dangerous and must be repaired.
3. **Store idle tools out of the reach of children and do not allow persons unfamiliar with the power tool or these instructions to operate the power tool.** Power tools are dangerous in the hands of untrained users.
4. **Maintain power tools. Check for misalignment or binding of moving parts, breakage of parts and any other condition that may affect the power tools operation. If damaged, have the power tool repaired before use.** Many accidents are caused by poorly maintained power tools.
5. **Keep cutting tools sharp and clean.** Poorly maintained cutting tools with sharp cutting edges are less likely to bind and are easier to control.
6. **Use the power tool and accessories in accordance with these instructions and in the manner intended for the particular type of power tool, taking into account the working conditions and the work to be performed.** Use of the power tool for operations different from intended could result in a hazardous situation.

HAMMER DRILL SAFETY INSTRUCTIONS

1. ONLY use the drill in the manner and for the functions described.
2. **Using the correct bit.** Use the appropriate drill bit for the material being drilled. Different bits are available from your Clarke dealer.
3. **Use of the mains cable.** Keep the mains cable well away from the drill and ensure an adequate electrical supply is close at hand so that the operation is not restricted by the length of the cable.
4. **Working on the bench.** Allow sufficient clearance beneath the work to ensure the drill bit does not come into contact with the floor, table etc.
5. **Switching off.** Never place the drill on a table or bench if it has not completely stopped. The drill bit will continue to rotate for a short time after the trigger has been released to stop the drill.
6. **Drilling into walls.** DO NOT drill into walls or cavities before checking for hidden electrical wires or water pipes etc.
7. **Finishing drilling.** DO NOT touch the drill bit immediately after use, allow time for it to cool.
8. **Use outdoor extension leads.** If working outdoors, ALWAYS use an

approved cable extension suitable for the power rating of this tool (see specifications), the conductor size should also be at least the same size as that on the machine, or larger. When using a cable reel, ALWAYS unwind the cable completely. We strongly recommend that this machine is connected to the mains supply via a Residual Current Device (RCD).

9. **Cooling agents.** When drilling metals, ALWAYS use a cooling agent i.e. cutting/soluble oil.

SERVICE

1. **Have your power tool serviced by a qualified repair person using only identical replacement parts.** This will ensure that the safety of the power tool is maintained.

SPECIFICATIONS

Item	Specification
Operating Modes	Drill or Drill & Hammer Action
Chuck Capacity	1.5 mm -13 mm
Rated No-load Speed	0 - 3000 rpm
Product weight	2 kg
Hammer Impact Rate	45000 blows/min
Rated Drilling Capacity (mm)	Wood, 25/ Steel, 12 / Masonary, 12
Dimensions (L x W x H)	291 x 70 x 245 mm
Operating voltage & Frequency	230V~50Hz
Fuse rating	13A
Motor Power	900W
Sound Pressure Level	90 dB LpA
Sound Power Level	101 dB LWA
Vibration using metal drill bit	Main handle 3.913 m/s ² , Aux. 2.838 m/s ²
Vibration using concrete drill bit	Main handle 15.378 m/s ² , Aux. 9.55 m/s ²

ELECTRICAL CONNECTIONS



WARNING: READ THESE ELECTRICAL SAFETY INSTRUCTIONS THOROUGHLY BEFORE CONNECTING THE PRODUCT TO THE MAINS SUPPLY.

This product may be fitted with a non-rewireable plug. If it is necessary to change the fuse in the plug, the fuse cover must be refitted. If the fuse cover becomes lost or damaged, the plug must not be used until a suitable replacement is obtained.

If the plug has to be changed because it is not suitable for your socket, or due to damage, it should be cut off and a replacement fitted, following the wiring instructions shown below. The old plug must be disposed of safely as insertion into a mains socket could cause an electrical hazard.

If the colours of the wires in the power cable of this product do not correspond with the markings on the terminals of your plug, proceed as follows.

- The **Blue** wire must be connected to the terminal which is marked **N** or coloured **Black**.
- The **Brown** wire must be connected to the terminal which is marked **L** or coloured **Red**.

Plug must be BS1363/A approved.

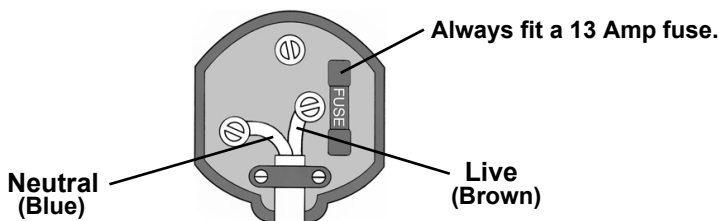

Ensure that the outer sheath of the cable is firmly held by the clamp

We strongly recommend that this machine is connected to the mains supply via a Residual Current Device (RCD)

If in any doubt, consult a qualified electrician. DO NOT attempt any repairs yourself.



This symbol indicates that this is a Class II product and does not require an earth connection.

OVERVIEW



The CHD900 is a variable-speed hammer drill designed for DIY use. It is equipped with a variable speed control and hammer operation. It also has a lock-on button for continuous operation.

When unpacking, check for damage or shortages etc. Any found should be reported to your CLARKE dealer where the drill was originally purchased. This drill is supplied with the following components:

- 1 x Hammer Drill
- 1 x Chuck Key
- 1 x Depth Stop Rod
- 1 x Auxiliary (Side) Handle

OPERATION

IMPORTANT: To avoid accidental starting, ensure the drill is switched OFF before plugging in to the mains. To do this, briefly pull the switch, and release to ensure the trigger lock is not set in the 'lock' position.

INSERTING A DRILL BIT

1. Open the chuck by rotating the chuck sleeve anticlockwise until the jaws are open sufficiently to take the drill bit.
2. Place the drill bit in the jaws of the chuck as far as it will go.
3. Insert the chuck key in one of the three holes in the chuck and tighten in a clockwise direction.
 - Make sure that the head of the chuck key is located on the cog barrel of the chuck when tightening.

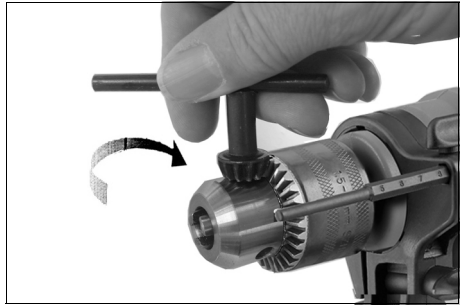

WARNING: TAKE CARE TO REMOVE THE CHUCK KEY BEFORE OPERATING THE DRILL.

-
- To remove the bit, release the jaws by inserting the chuck key in one of the holes and turning in an anticlockwise direction.

SWITCHING ON & CONTINUOUS OPERATION

1. Plug into a 13amp socket and squeeze the trigger to start the drill.
2. During use, press the trigger lock-on button and the drill will run continuously. Squeeze the trigger again briefly to release the trigger lock & stop the drill.

HAMMER DRILL SELECTION

Slide the drill/hammer drill mode selector switch to the 'Hammer' symbol on the drill body.

NORMAL DRILL SELECTION

Slide the drill/hammer drill mode selector switch to the 'Drill' symbol on the drill body.

NOTE: Both these actions should only be performed when the drill is at a complete stop.

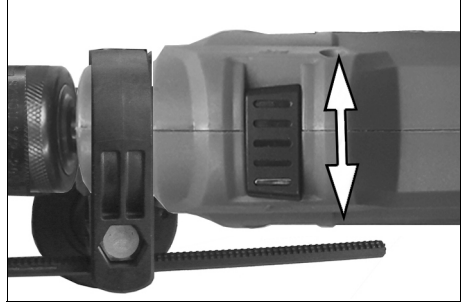

FORWARD / REVERSE SELECTION

1. Set the forward/reverse selector switch to the normal 'Right Hand' (forward) rotation for drilling holes.
2. Set the forward/reverse selector switch to the opposite position for 'Left Hand' (reverse) rotation to reverse the drill out of the workpiece.

NOTE: This operation should only be performed when the drill is at a complete stop.



SPEED SELECTION

1. Turn the variable speed control in the centre of the trigger until the drill runs at your chosen speed.
2. The drill can be locked running by pressing the lock-on button after the trigger is squeezed.
3. To stop the drill, just squeeze the trigger again.



AUXILIARY HANDLE

1. Fit the handle by loosening it off prior to sliding it over the chuck and onto the body of the drill.
2. Rotate the handle to the desired position and secure in position using the thumbscrew.

DEPTH STOP

1. The depth stop is fitted within the auxiliary handle and can only be used if the handle is installed.
2. Insert the depth stop rod through the holder in the handle assembly.
3. Slide the rod in and out to the required position. Lock in place by turning the thumbscrew.



GENERAL DRILLING TECHNIQUE

- After drilling material to the full depth, maintain chuck rotation to ease drill withdrawal.
- If the drill is not cutting the metal then sharpen the drill bit, ensuring the various cutting angles are correct.
- ALWAYS use sharp, good quality drill bits. The performance of your drill is dependant on the quality of the bits used.
- Reduce the pressure on the drill bit when it is about to break through. This will prevent the drill from jamming.
- If drilling a large hole, first drill a pilot hole using a smaller drill bit.
- ALWAYS apply pressure to the drill bit in a straight line and at right angles to the workpiece. Do not use sideways movement as this may damage the drill or cause the bit to break.
- When drilling holes or driving screws into walls, floors etc., always make sure that there are no live electrical wires in the path of the drill
- When drilling metal, it can become hot. To reduce overheating use a suitable cooling lubricant. No cooling lubricant is necessary when drilling cast iron or brass as they should be drilled dry.
- When drilling metal, the harder the metal, the slower the drill speed. Likewise, the larger the drill bit the slower the speed.
- To prevent the drill bit from slipping when starting to drill a hole in metal, use a centre punch to make an indentation at the start point.

- ALWAYS start drilling at the slowest speed to prevent the drill from slipping out of the pop mark or indent.
- Select the speed according to the drill bit being used whilst maintaining a MODERATE pressure ONLY. NEVER force the drill bit into the work. This will overheat the tip and cause it to dull very quickly.
- When drilling in wood, clamp a piece of scrap wood to the underside of the material to avoid splintering.
- ALWAYS drill directly in line with the bit. Do not use sideways movement as this may damage the drill or cause the bit to break.
- Large holes should be drilled with wood augers, flat wood bits or hole saws.

MAINTENANCE

Before any maintenance procedures, always ensure the drill is isolated from the power supply by switching off and unplugging from the socket.

BEFORE USE

1. Inspect the power cable to ensure it is in good condition.

CLEANING

1. Ensure all air ventilation slots are clear of blockages, (use compressed air to clean the machine if possible). Wear protective goggles if using compressed air.
2. After use, clean all dust and swarf from the drill with a soft cleaning cloth. Never use any chemicals/ solvents or harsh abrasives to clean the drill.

GENERAL MAINTENANCE

- All bearings etc, in this tool are lubricated with a sufficient amount of high grade lubricant for the tools lifetime under normal operating conditions, therefore no further lubrication is necessary.
- Refer to your CLARKE dealer if internal maintenance is required.

FAULTFINDING

Problem	Possible Cause	Remedy
Tool will not operate	No power supply	Check supply & rectify as necessary
	Switch is faulty	Consult your CLARKE dealer
	Fuse blown	Check & replace if necessary
	Motor is faulty	Consult your CLARKE dealer
Motor runs but drill bit does not move.	Drill fastening not tight	Secure drill bit
	Drive gear broken	Consult your CLARKE dealer
Heavy internal sparking	Faulty motor	Consult your CLARKE dealer
	Worn brushes	Consult your CLARKE dealer
Motor becomes hot	Unduly heavy use	Reduce the force applied to the drill bit. Let the tool do the work
	Air vent have become blocked	Clean out the air vents using compressed air or clean with a dry cloth
	Low supply voltage	Ensure supply voltage is correct. If an extension cable is used, ensure it is the correct rating and is fully unwound
Excessive vibration.	Drill bit bent or not mounted correctly	Check and rectify
	Machine bearings worn	Consult your CLARKE dealer

COMPONENT PARTS LIST

No	Description
1	Chuck Retaining Screw
2	Chuck
3	Drive Spindle
4	Woodruff Key
5	Impact Spring
6	Bearing 6001
7	Carbon Brush Holder
8	Gear
9	Circlip 9mm
10	Copper bush
11	Supporting rack
12	Impact Selector
13	Impact piece
14	Motor Bearing 608
15	Motor Rotor
16	Right Carbon Brush holder
17	Left Carbon Brush Holder
18	Carbon brush

No	Description
19	Disc spring
20	Screw S/t3x10
21	607 Bearing
22	Motor Stator
23	Casing (RH)
24	Casing Screw ST4x16
25	Direction button
26	Inductor
27	Switch
28	Capacitor 22uf
29	Screw ST4x14
30	Cable gland
31	Casing (LH)
32	Cable sleeve
33	Power Cable & Plug
34	Depth Stop Rod
35	Auxiliary Handle

An extensive selection of accessories including Drill Bit Sets, Socket & Bit Sets and Drill Bit Sharpeners are available from your CLARKE dealer.

The following drill bit sets are suggested for use with your hammer drill.

CHT342 - 30 Piece Titanium Coated HSS Drill Set (Imperial Sizes) Part No: 1801342

CHT348 - 30 Piece Titanium Coated HSS Drill Set (Metric Sizes) Part No: 1801348

Titanium coated HSS bits last up to 6 times longer than standard bits which can be sharpened using a Clarke Drill Sharpener such as the CBS43 or the CBS16.

CHT383 - 19 Piece (Metric) Cobalt Steel Drill Set Part No: 1801383

CHT384 - 25 Piece (Metric) Cobalt Steel Drill Set Part No: 1801384

Suitable for drilling carbon steel, super alloys, titanium and stainless steel.

COMPONENT PARTS

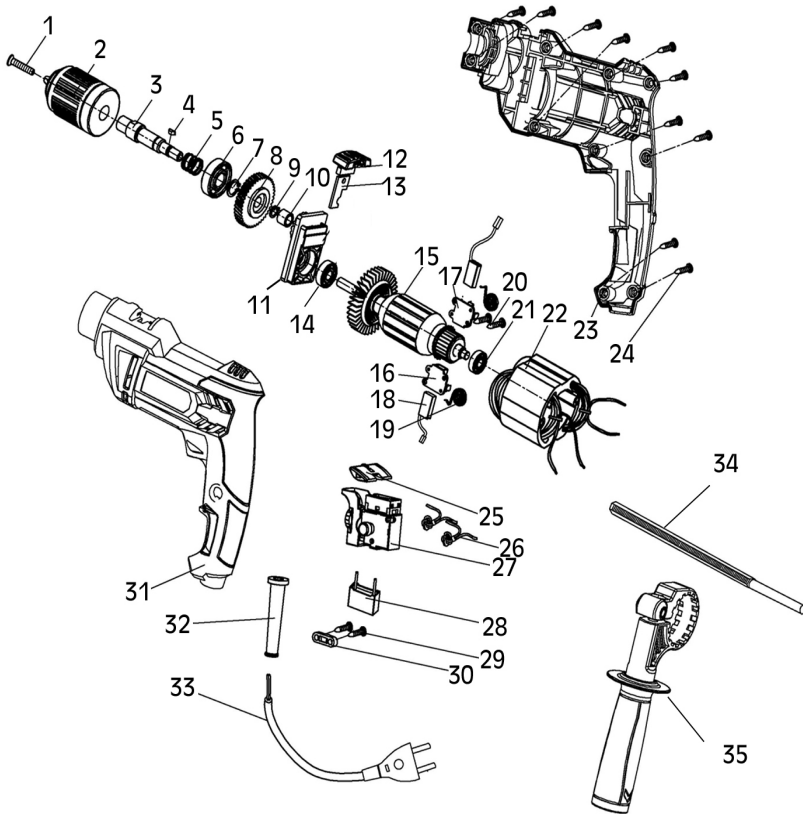

GUARANTEE

This product is guaranteed against faulty manufacture for a period of 12 months from the date of purchase. Please keep your receipt which will be required as proof of purchase.

This guarantee is invalid if the product is found to have been abused or tampered with in any way, or not used for the purpose for which it was intended.

Faulty goods should be returned to their place of purchase, no product can be returned to us without prior permission. This guarantee does not effect your statutory rights.

DECLARATIONS OF CONFORMITY



Fitzwilliam Hall, Fitzwilliam Place, Dublin 2

DECLARATION OF CONFORMITY

This is an important document and should be retained.

We hereby declare that this product(s) complies with the following directive(s):

- 2014/30/EU Electromagnetic Compatibility Directive
- 2006/42/EC Machinery Directive
- 2011/65/EU Restriction of the Use of Certain Hazardous Substances in Electrical and Electronic Equipment Directive

The following standards have been applied to the product(s):

- EN 55014-1:2017, EN 55014-2:2015, EN/IEC 61000-3-2:2019, EN 61000-3-3:2013+A1, EN 62841-1:2015, EN 62841-2:2018, IEC 62321-1:2013, IEC 62321-2:2013, IEC 62321-3-1:2013, IEC 62321-4:2013, IEC 62321-5:2013, IEC 62321-6:2015, IEC 62321-7-1:2015, EN 62321:2009 Annex C, ISO 17075:2007.

The technical documentation required to demonstrate that the product(s) meet(s) the requirement(s) of the aforementioned directive(s) has been compiled and is available for inspection by the relevant enforcement authorities.

The CE mark was first applied in: 2022

Product Description: Hammer Drill 230V
 Model number(s): CHD900
 Serial / batch Number: N/A
 Date of issue: 25/08/2022

Signed:

J.A. Clarke
Director

CHD900 CE Clarke DOC 083322

Page 1 of 1



Hemmill Street, Epping, Essex CM16 4LG

DECLARATION OF CONFORMITY

This is an important document and should be retained.

We hereby declare that this product(s) complies with the following statutory requirement(s):

- Electromagnetic Compatibility Regulations 2016
- Supply of Machinery (Safety) Regulations 2008
- The Restriction of the Use of Certain Hazardous Substances in Electrical and Electronic Equipment Regulations 2012

The following standards have been applied to the product(s):

- EN 55014-1:2017, EN 55014-2:2015, EN/IEC 61000-3-2:2019, EN 61000-3-3:2013+A1, EN 62841-1:2015, EN 62841-2:2018, IEC 62321-1:2013, IEC 62321-2:2013, IEC 62321-3-1:2013, IEC 62321-4:2013, IEC 62321-5:2013, IEC 62321-6:2015, IEC 62321-7-1:2015, EN 62321:2009 Annex C, ISO 17075:2007.

The technical documentation required to demonstrate that the product(s) meet(s) the requirement(s) of the aforementioned legislation has been compiled and is available for inspection by the relevant enforcement authorities.

The UKCA mark was first applied in: 2022

Product Description: Hammer Drill 230V
 Model number(s): CHD900
 Serial / batch Number: N/A
 Date of issue: 25/08/2022

Signed:

J.A. Clarke
Director

CHD900 UKCA Clarke DOC 083322

Page 1 of 1

A SELECTION FROM THE VAST RANGE OF

Clarke®

QUALITY PRODUCTS



AIR COMPRESSORS

From DIY to industrial, Plus air tools, spray guns and accessories.

GENERATORS

Prime duty or emergency standby for business, home and leisure.

POWER WASHERS

Hot and cold, electric and engine driven - we have what you need

WELDERS

Mig, Arc, Tig and Spot. From DIY to auto/industrial.

METALWORKING

Drills, grinders and saws for DIY and professional use.

WOODWORKING

Saws, sanders, lathes, mortisers and dust extraction.

HYDRAULICS

Cranes, body repair kits, transmission jacks for all types of workshop use.

WATER PUMPS

Submersible, electric and engine driven for DIY, agriculture and industry.

POWER TOOLS

Angle grinders, cordless drill sets, saws and sanders.

STARTERS/CHARGERS

All sizes for car and commercial use.

PARTS & SERVICE: 0208 988 7400

Parts Enquiries
Parts@clarkeinternational.com

Servicing & Technical Enquiries
Service@clarkeinternational.com

SALES: UK 01992 565333 or Export 00 44 (0)1992 565335

Clarke INTERNATIONAL Hemnall Street, Epping, Essex CM16 4LG
www.clarkeinternational.com